

## TO-220F Plastic-Encapsulate Diodes

### MBR10200FCT SCHOTTKY BARRIER RECTIFIER

#### FEATURES

- Schottky Barrier Chip
- Guard Ring Die Construction for Transient Protection
- Low Power Loss, High Efficiency
- High Surge Capability
- High Current Capability and Low Forward Voltage Drop
- For Use in Low Voltage, High Frequency Inverters, Free Wheeling, and Polarity Protection Applications

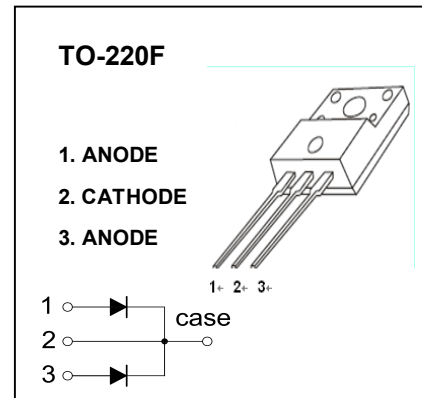

#### MAXIMUM RATINGS ( $T_a=25^{\circ}\text{C}$ unless otherwise noted )

Symbol	Parameter	Value	Unit
$V_{RRM}$	Peak repetitive reverse voltage	200	V
$V_{RWM}$	Working peak reverse voltage		
$V_R$	DC blocking voltage		
$V_{R(RMS)}$	RMS reverse voltage	140	V
$I_O$	Average rectified output current	10	A
$I_{FSM}$	Non-Repetitive peak forward surge current 8.3ms half sine wave	120	A
$P_D$	Power dissipation	2	W
$R_{\theta JA}$	Thermal resistance from junction to ambient	50	$^{\circ}\text{C}/\text{W}$
$T_j$	Junction temperature	125	$^{\circ}\text{C}$
$T_{stg}$	Storage temperature	-55~+150	$^{\circ}\text{C}$

#### ELECTRICAL CHARACTERISTICS ( $T_a=25^{\circ}\text{C}$ unless otherwise specified )

Parameter	Symbol	Test conditions	Min	Typ	Max	Unit
Reverse voltage	$V_{(BR)}$	$I_R=0.1\text{mA}$	200			V
Reverse current	$I_R$	$V_R=200\text{V}$			50	$\mu\text{A}$
Forward voltage	$V_{F1}$	$I_F=5\text{A}$			0.92	V
	$V_{F2}^*$	$I_F=10\text{A}$			1.1	
Typical total capacitance	$C_{tot}$	$V_R=4\text{V}, f=1\text{MHz}$		50		pF

\*Pulse test

# Typical Characteristics

# MBR10200FCT

Forward Characteristics

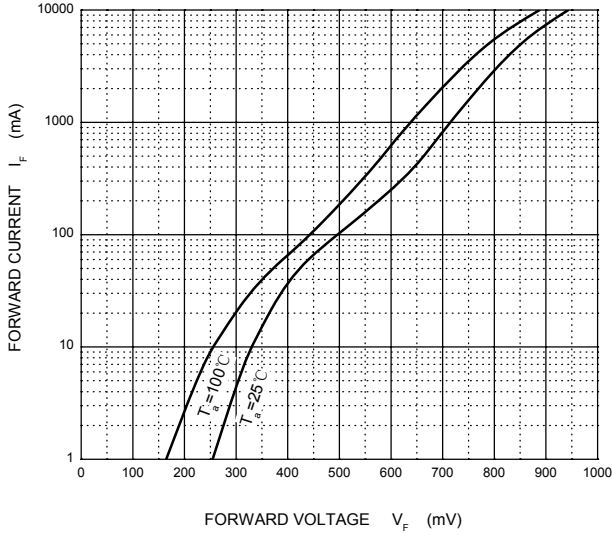

Reverse Characteristics

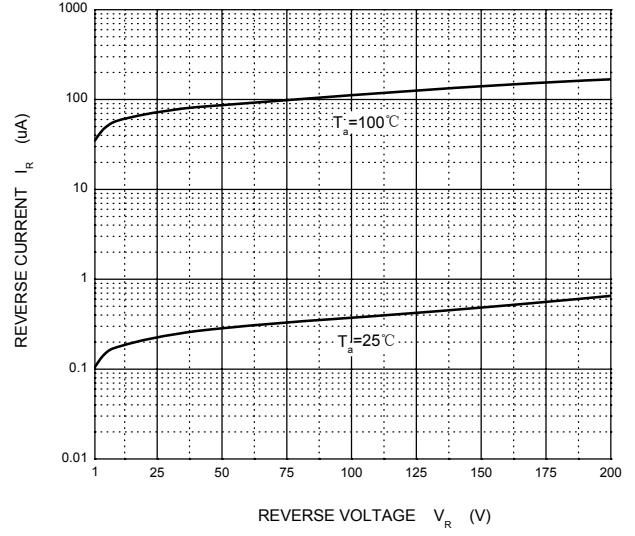

Capacitance Characteristics

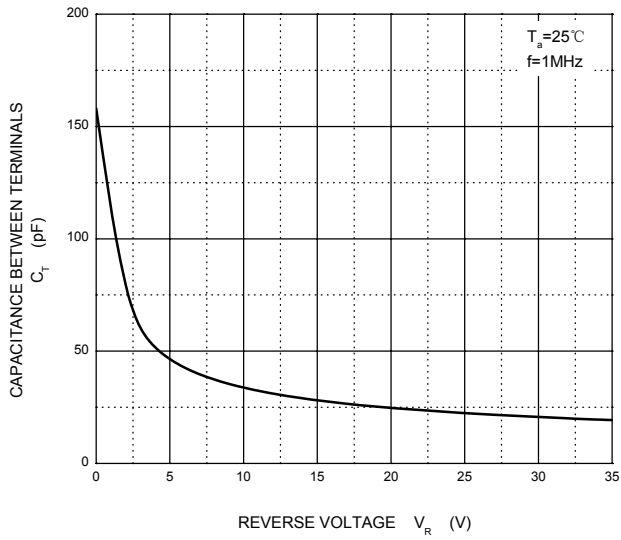

Power Derating Curve

