

Digital Transistors (Built-in Resistors)

EMD38 General purpose digital transistor (NPN+PNP)

FEATURES

- DTr1:NPN digital transistor,DTC114Y
DTr2:PNP digital transistor,DTA113Z
- Mounting possible with SOT-563 automatic mounting machines

APPLICATIONS

Driver

Marking: D38

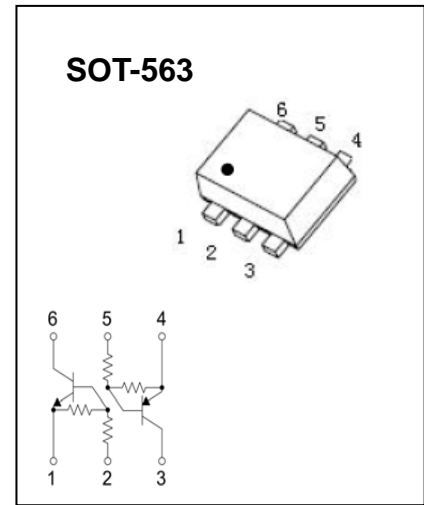

DTr1 Absolute maximum ratings ($T_a=25^\circ\text{C}$)

Parameter	Symbol	Value	Unit
Supply voltage	V_{CC}	50	V
Input voltage	V_{IN}	-6~+40	V
Output current	I_o	70	mA
	$I_{C(MAX)}$ *	100	
Power dissipation	P_d	150	mW
Junction temperature	T_j	150	$^\circ\text{C}$
Storage temperature	T_{stg}	-55~+150	$^\circ\text{C}$

*Characteristics of built-in transistor.

Electrical characteristics ($T_a=25^\circ\text{C}$)

Parameter	Symbol	Min	Typ	Max	Unit	Conditions
Input voltage	$V_{I(off)}$	0.3			V	$V_{CC}=5V, I_o=100\mu\text{A}$
	$V_{I(on)}$			1.4		$V_o=0.3V, I_o=1\text{mA}$
Output voltage	$V_{O(on)}$			0.3	V	$I_o=5\text{mA}, I_i=0.25\text{mA}$
Input current	I_i			0.88	mA	$V_i=5V$
Output current	$I_{O(off)}$			0.5	μA	$V_{CC}=50V, V_i=0$
DC current gain	G_I	68				$V_o=5V, I_o=5\text{mA}$
Input resistance	R_1	7	10	13	K Ω	
Resistance ratio	R_2/R_1	3.7	4.7	5.7		
Transition frequency	f_T		250		MHz	$V_o=10V, I_o=5\text{mA}, f=100\text{MHz}$

DTr2 Absolute maximum ratings ($T_a=25^\circ\text{C}$)

Parameter	Symbol	Value	Unit
Supply voltage	V_{CC}	-50	V
Input voltage	V_{IN}	-10~+5	V
Output current	I_O	-70	mA
	$I_{C(MAX)}^*$	-100	
Power dissipation	P_d	150	mW
Junction temperature	T_j	150	$^\circ\text{C}$
Storage temperature	T_{stg}	-55~+150	$^\circ\text{C}$

*Characteristics of built-in transistor.

Electrical characteristics ($T_a=25^\circ\text{C}$)

Parameter	Symbol	Min	Typ	Max	Unit	Conditions
Input voltage	$V_{I(off)}$	-0.3			V	$V_{CC}=-5V, I_O=-100\mu\text{A}$
	$V_{I(on)}$			-3		$V_O=-0.3V, I_O=-20\text{mA}$
Output voltage	$V_{O(on)}$			-0.3	V	$I_O=-10\text{mA}, I_I=-0.5\text{mA}$
Input current	I_I			-7.2	mA	$V_I=-5V$
Output current	$I_{O(off)}$			-0.5	μA	$V_{CC}=-50V, V_I=0$
DC current gain	G_1	33				$V_O=-5V, I_O=-5\text{mA}$
Input resistance	R_1	0.7	1	1.3	K Ω	
Resistance ratio	R_2/R_1	8	10	12		
Transition frequency	f_T		250		MHz	$V_O=-10V, I_O=-5\text{mA}, f=100\text{MHz}$

SOT-563 Package Outline Dimensions

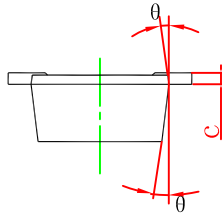
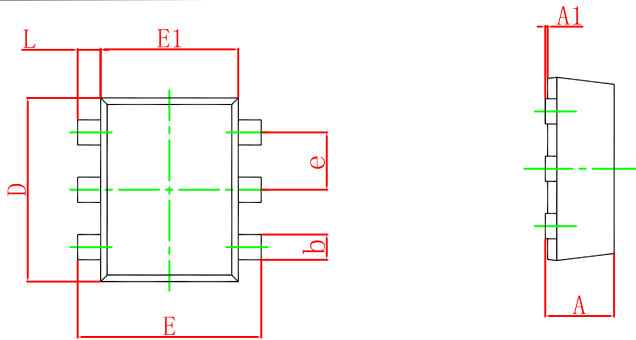

Symbol	Dimensions In Millimeters		Dimensions In Inches	
	Min.	Max.	Min.	Max.
A	0.525	0.600	0.021	0.024
A1	0.000	0.050	0.000	0.002
e	0.450	0.550	0.018	0.022
c	0.090	0.160	0.004	0.006
D	1.500	1.700	0.059	0.067
b	0.170	0.270	0.007	0.011
E1	1.100	1.300	0.043	0.051
E	1.500	1.700	0.059	0.067
L	0.100	0.300	0.004	0.012
θ	7° REF.		7° REF.	

SOT-563 Suggested Pad Layout

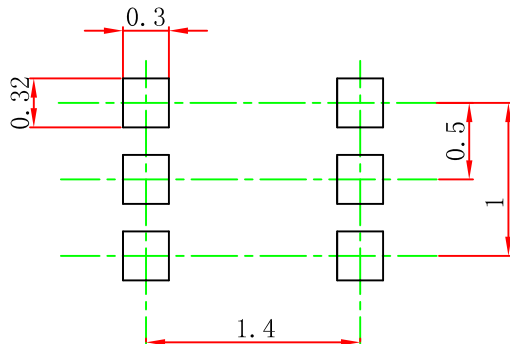

Note:

1. Controlling dimension: in millimeters.
2. General tolerance: ± 0.05 mm.
3. The pad layout is for reference purposes only.

NOTICE

JCET reserve the right to make modifications, enhancements, improvements, corrections or other changes without further notice to any product herein. JCET does not assume any liability arising out of the application or use of any product described herein.

SOT-563 Tape and reel

SOT-563 Embossed Carrier Tape

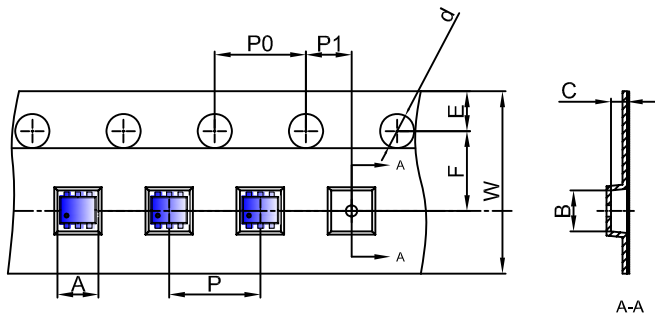

Packaging Description:

SOT-563 parts are shipped in tape. The carrier tape is made from a dissipative (carbon filled) polycarbonate resin. The cover tape is a multilayer film (Heat Activated Adhesive in nature) primarily composed of polyester film, adhesive layer, sealant, and anti-static sprayed agent. These reeled parts in standard option are shipped with 3,000 units per 7" or 17.8cm diameter reel. The reels are clear in color and is made of polystyrene plastic (anti-static coated).

Dimensions are in millimeter										
Pkg type	A	B	C	d	E	F	P0	P	P1	W
SOT-563	1.78	1.78	0.69	Ø1.50	1.75	3.50	4.00	4.00	2.00	8.00
(Tolerance)	+/-0.1	+/-0.1	+/-0.1	+/-0.1	+/-0.1	+/-0.1	+/-0.1	+/-0.1	+/-0.1	+/-0.1

SOT-563 Tape Leader and Trailer

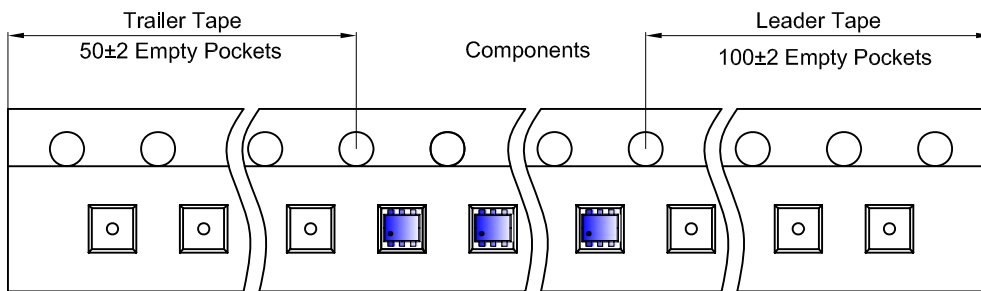

SOT-563 Reel

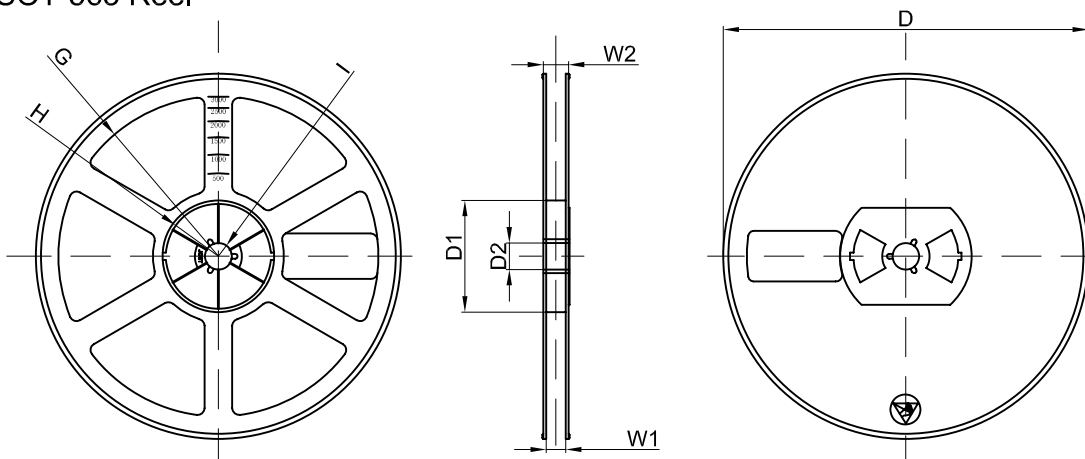

Dimensions are in millimeter								
Reel Option	D	D1	D2	G	H	I	W1	W2
7" Dia	Ø178.00	54.40	13.00	R78.00	R25.60	R6.50	9.50	12.30
Tolerance	+/-2	+/-1	+/-1	+/-1	+/-1	+/-1	+/-1	+/-1

REEL	Reel Size	Box	Box Size(mm)	Carton	Carton Size(mm)	G.W.(kg)
3000 pcs	7 inch	45,000 pcs	203×203×195	180,000 pcs	438×438×220	